

FAAC

Hydraulic Underground automation for swing gates using 24V

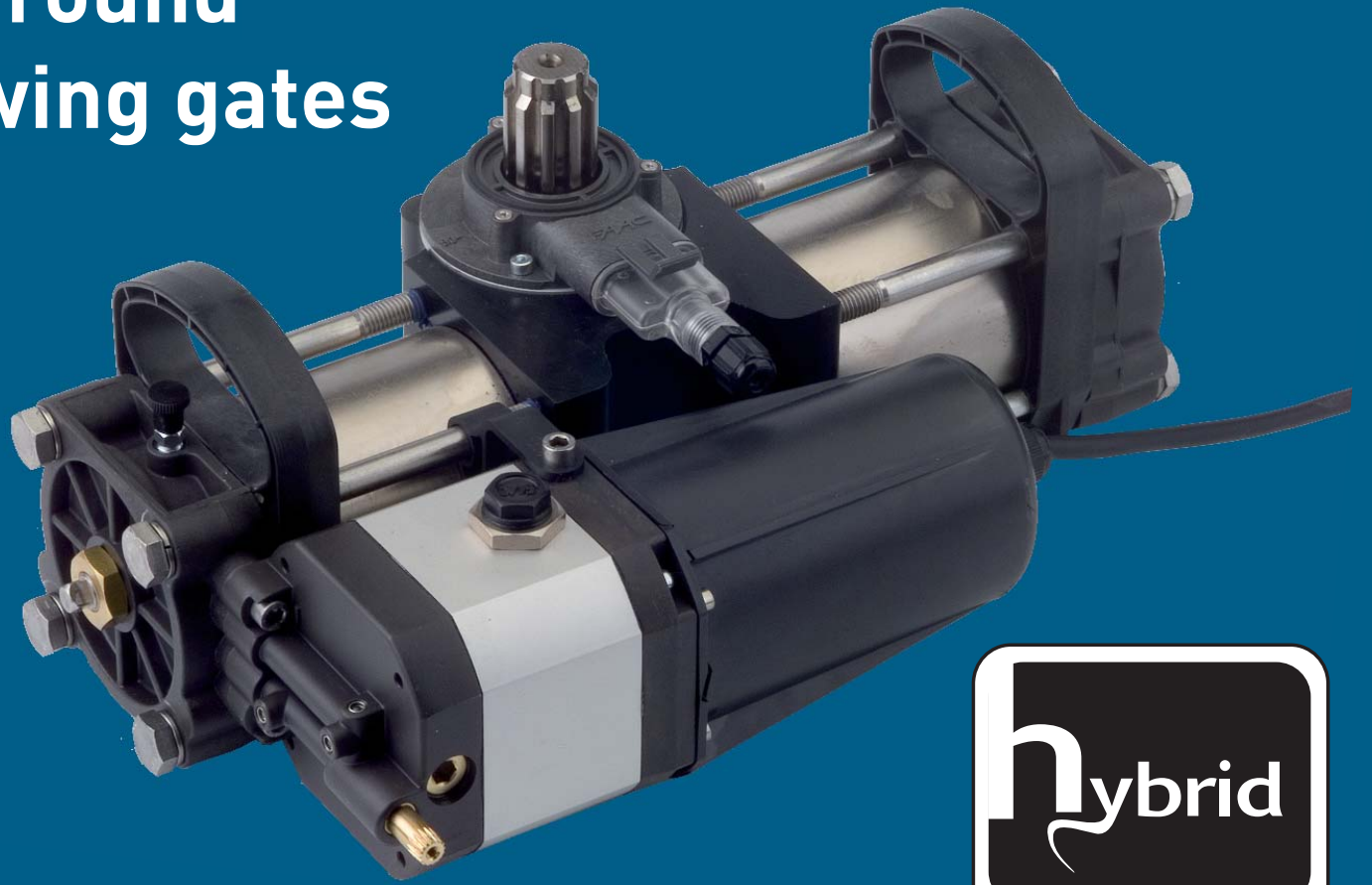

S700 Range

The S700 is a hybrid operator, using hydraulics with 24V power. It is suitable for gate leaves up to 4m wide and weighing 800kgs.



Reliable. Affordable. Dependable.

FAAC

...Leading the way.



Excellence in Automation

S700 Range

A new milestone in Underground automation

The S700 operator is a hybrid. It combines hydraulic technology and 24 Vdc motor. This makes it energy efficient using 45% less power compared to a 230 Volt hydraulic operator. Units are available with (CBAC) or without (SB) hydraulic locking with 100° or 180° opening versions.

Intelligence

The operator has an innovative encoder, which is mounted around the drive pinion. It monitors the position of the gate. If an obstruction is encountered during the movement cycle, the gate will reverse its movement.

Foundation box

The foundation box, into which the automation is fitted is made of steel, and acts as a load bearing bottom hinge for the gate. It has a flat bottom with ducts for drainage. There is also a reinforced collar housing. The collar is mounted in a modern self lubricating bush. The operator is now easier to fit into the foundation box, as just 2 bolts are required. Servicing has also been made simpler with the oil filler cap conveniently located in a highly accessible area.

Known for its extensive range of high quality products and innovative manufacturing techniques, FAAC continue to engineer reliable, versatile, cutting edge automation systems, chosen for residential and commercial installations on a worldwide basis. Providing high quality automation systems for gates, barriers, doors, parking and access control products, FAAC is the leading brand in the automation market.

Dimensions

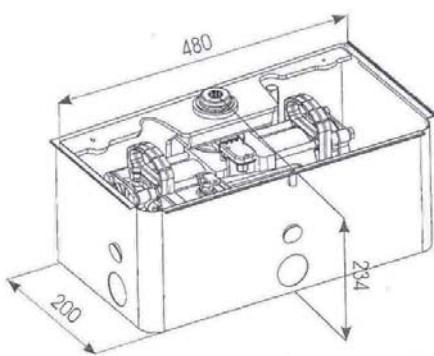

SB - without hydraulic locking

Standard version

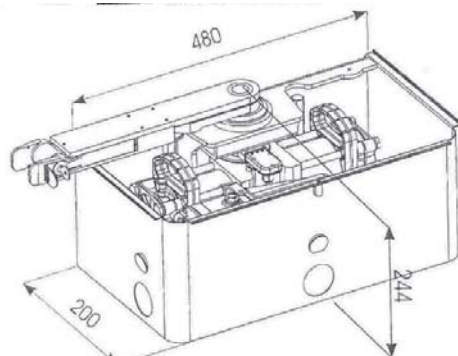

CBAC - with hydraulic locking

Version with mechanical release (optional)

Installation layout

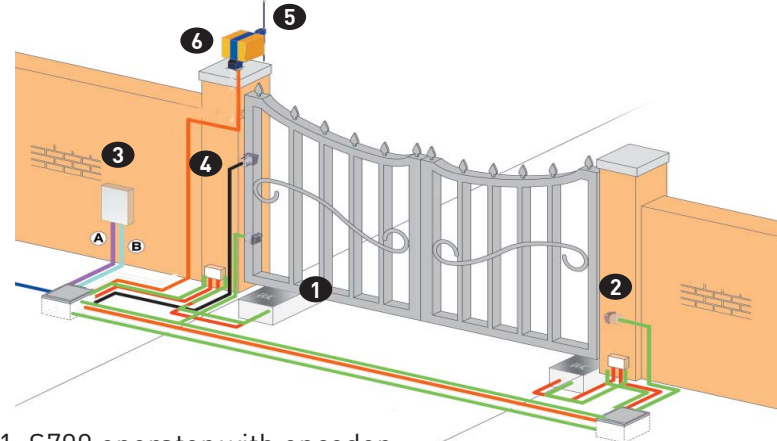

1. S700 operator with encoder (provide two pullboxes)
2. Photocells
3. Control unit
4. Key-operated push button
5. Receiver
6. Flashing lamp

Low voltage cabling		Power cabling (230V)	
A	{ cables 3x 0.5 2 cables 2x 0.5 2 cables 2x 2.5	B	{ 1 cable 2x2.5+E
NB: Cable diameters in mm ²			

S700 Technical Specifications

Model	CBAC Operator	SB Operator
Power supply:	230V	
Absorbed power :	120W	
Electric motor:	24Vdc	
Protection class:	IP67	
Type of oil:	FAAC HP Oil	
Operating ambient temperature:	-20°C +55°C	
Use frequency:	100%	
Hydraulic locking:	YES	NO
Pump flow rate: (l/min)	0.5	
Max. torque (Nm)**	500 (E700)	600 (E124)
Angular speed (°/sec)***	5.5 (E700)	8.2 (E124)
Max opening angle	(S700 100°) (S700 180°)	
Type of slow-down	electronic	
Leaf max. length (m)	1.8	4
leaf max. weight (kg)	800	

** Considering 55 bar of static pressure in the chambers

*** Considering a pump capacity of 0.6 lpm

Additional Characteristics

- Built in adjustable stops for open and closed position
- Encoder for positional tracking and safety
- Simple, secure and robust lever manual release
- Easy installation

